

GOLD CUP[®] M11-14 F/G/M/N Options Spare Parts Manual

High Pressure Axle Piston Motors

HY28-2682-03/GC/US

Effective: December 1, 2012



ENGINEERING YOUR SUCCESS.

Hydraulic Pump and Power Systems Division and Denison Hydraulics

The Hydraulic Pump and Power Systems Division of Parker Hannifin was formed in 2004 when our significant piston pump business was expanded through the acquisition of **Denison Hydraulics**. The addition of **Denison** allowed us to marry the wealth of knowledge that both companies have in the design, manufacture, and application of piston products in both open circuit and closed circuit system applications. Since before WWII, **Denison** products have been chosen for Military test stand applications and for shipboard hydraulic applications being recognized as technology leaders.

The heavy duty **GOLD CUP®** series of pumps and motors in this catalog represent a broadening of our product offering with hydrostatic transmission applications in marine, drilling, and shredding applications, among others. The tried and true design of the **GOLD CUP®** product line incorporates features such as integral servo and replenishing pump, hot oil shuttle, and a unique servo control system; all of which combine to provide a rugged self contained package which can withstand the harshest of conditions and continue to perform with trouble free long life.

The division is a leading worldwide manufacturer of hydraulic components and systems for earthmoving and construction vehicles; for mining equipment; for pulp and paper, chemical and other processing equipment; for ships and ordnance equipment; and for such in-plant machines as machine tools, plastic molding, die casters, and stamping presses.



The product information, specifications, and descriptions contained in this publication have been compiled for the use and convenience of our customers from information furnished by the manufacturer; and we can not, and do not, accept any responsibility for the accuracy or correctness of any description, calculation, specification, or information contained herein. No such description, calculation, specification, or information regarding the products being sold has been made part of the basis of the bargain, nor has same created or amounted to an express warranty that the products would conform thereto. We are selling the goods and merchandise illustrated and described on this publication on an "as is" basis, and disclaim any implied warranty, including any warranty of merchantability or warranty of fitness for any particular purpose whatsoever, with respect to the goods and merchandise sold. All manufacturer warranties shall be passed on to our customers, but we shall not be responsible for special, indirect, incidental, or consequential damages resulting from the use of any of the products or information contained or described on this publication. Further, we reserve the right to revise or otherwise make product improvements at any time without notification.



WARNING - USER RESPONSIBILITY

FAILURE OR IMPROPER SELECTION OR IMPROPER USE OF THE PRODUCTS DESCRIBED HEREIN OR RELATED ITEMS CAN CAUSE DEATH, PERSONAL INJURY AND PROPERTY DAMAGE.

This document and other information from Parker-Hannifin Corporation, its subsidiaries and authorized distributors provide product or system options for further investigation by users having technical expertise.

The user, through its own analysis and testing, is solely responsible for making the final selection of the system and components and assuring that all performance, endurance, maintenance, safety and warning requirements of the application are met. The user must analyze all aspects of the application, follow applicable industry standards, and follow the information concerning the product in the current product catalog and in any other materials provided from Parker or its subsidiaries or authorized distributors.

To the extent that Parker or its subsidiaries or authorized distributors provide component or system options based upon data or specifications provided by the user, the user is responsible for determining that such data and specifications are suitable and sufficient for all applications and reasonably foreseeable uses of the components or systems.

OFFER OF SALE

The items described in this document are hereby offered for sale by Parker-Hannifin Corporation, its subsidiaries or its authorized distributor. This offer and its acceptance are governed by the provisions stated in the detailed "Offer of Sale" elsewhere in this document.

Design Series – A

Motor Ordering Code2
M11/14 Motor Type F/G Sectional Views4
M11/14 Motor Type M/N Sectional Views6
Section View - A - Input Shaft, Seal Retainer Assembly & Associated Kits8
Section View - B - Housing, Barrel Bearing Assembly & Associated Kits 12
Section View - C - Rotating Group Assembly & Associated Kits..... 14
Section - D - Motor Type F & G Port Block Assembly & Associated Kits 18
Section - D - Motor Type M & N Port Block Assembly & Associated Kits 22
Offer of Sale27

Notes:

1. Parts list and associated drawings shown in this bulletin are for standard model motor only. All documentation for special “M2” modification motor model numbers must be verified with an HPS Factory Representative prior to ordering parts for such products.
2. * Indicates Special Instructions or Considerations.
3. ** Indicates Common Parts.
4. N/A Indicates Not Available or Not Applicable.
5. All documentation represented in this bulletin is for standard production model Fixed Displacement Motors Design Level “A”.
6. See ordering code for configuration options.
7. All orientation references are described when viewing motor from main drive shaft with D1 port @ the 12 o'clock position.
8. Assembly part numbers with - 0 suffixes, indicate Buna N (Nitrile) seal compound. For Ethylene Propylene, (EPR), compound, use - 4 suffix. For Fluorocarbon compound use - 5 suffixes.
9. Detail part numbers for O-rings with 671 / 691 prefix, indicate Buna N (Nitrile) seal compound. For Ethylene Propylene, (EPR), compound, use 674 / 694 prefix. For Fluorocarbon compound use 675 / 695 prefix.
10. Drawings with items marked with double balloons “◎”, indicate assemblies.



Code	Displacement
6	6.00 in ³ /rev (98cc/rev)
7	7.25 in ³ /rev (119 cc/rev)
8	8.00 in ³ /rev (131 cc/rev)
11	11.0 in ³ /rev (180 cc/rev)
14	14.0 in ³ /rev (229 cc/rev)
24	24.6 in ³ /rev (403 cc/rev)
30	30.6 in ³ /rev (501 cc/rev)

Code	Type
F	Fixed Displacement
G	Fixed Displacement with Shuttle Package
M	Fixed Displacement with Thru-Drive
N	Fixed Displacement with Thru-Drive & Shuttle Package
V	Variable Displacement
H	Variable Displacement with Shuttle Package
R	Variable Displacement with Thru-Drive
L	Variable Displacement with Thru-Drive & Shuttle Package

Code	Efficiency
H	High Efficiency (M24 only)
Omit	Standard Efficiency

Code	Shaft
2	Keyed SAE – Mechanical Shaft Seal (Single Lip Seal on M6, 7, 8F/G/M/N)
3	Splined SAE – Mechanical Shaft Seal (Single Lip Seal on M6, 7, 8F/G/M/N)
4	Keyed SAE-D (Mounting & Shaft) – Mechanical Shaft Seal (M6, 7 & 8 only, Single Lip Seal on Fixed Displacement Motors)
5	Splined SAE-D (Mounting & Shaft) – Mechanical Shaft Seal (P6, 7 & 8 only, Single Lip Seal on Fixed Displacement Motors)
7	Keyed SAE – Double Lip Shaft Seal
8	Splined SAE – Double Lip Shaft Seal
9	Keyed (long) SAE – Double Lip Shaft Seal
10	Keyed (long) SAE – Mechanical Shaft Seal

Code	Seals
1	Nitrile (Buna-N)
4	EPR ³
5	Fluorocarbon

Code	Primary Controls
Omit	None (Fixed Displacement only)
2A	Cylinder Control w/Adjustable Maximum Volume Stops
2M	Cylinder Control – 2-Position Electrohydraulic w/Adjustable Maximum Volume Stop (Spring Offset to Maximum Displacement) ¹
5A	Electrohydraulic Stroker w/ Adjustable Maximum Volume Stops ¹
8A	Hydraulic Stroker w/Adjustable Maximum Volume Stops
9A	Electrohydraulic Stroker w/ Adjustable Maximum Volume Stops ¹

Code	Secondary Controls
Omit	None (Fixed Displacement only)
0	Volume Indicator
3	Reverse Compensator (spring offset to maximum displacement) + Volume Indicator
5	Reverse Compensator (spring offset to minimum displacement) + Volume Indicator
6	Cam Position Feedback Potentiometer ¹
7	Cam Position Feedback RVDT (AC) ¹
8	Cam Position Feedback RVDT (DC) ¹
U	Reverse Compensator (3) + Cam Position Feedback Potentiometer (6) ¹
W	Reverse Compensator (3) + Cam Position Feedback RVDT (8) ¹
X	Reverse Compensator (5) + Cam Position Feedback Potentiometer (6) ¹
Z	Reverse Compensator (5) + Cam Position Feedback RVDT (8) ¹

Code	Control Location
Omit	None (Fixed Displacement only)
A	Primary Control on Port A Side
B	Primary Control on Port B Side

 = Omit if not required

1 Not ATEX approved.
2 Assigned by manufacturer.
3 Not available when using "5A" primary control. Motor will be unpainted unless otherwise specified.

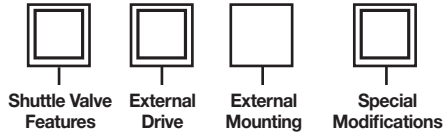
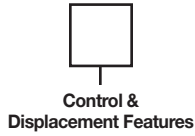

Control	Code	Control & Displacement Features
2M	0	CETOP3, NG6 Valve, 110AC/60Hz with Hirschmann Connector ¹
	1	CETOP3, NG6 Valve, 12VDC with Hirschmann Connector ¹
	2	CETOP3, NG6 Valve, 240VAC/50Hz with Hirschmann Connector ¹
	3	CETOP3, NG6 Valve, 110VAC/60Hz, Wiring Box ¹
	4	CETOP3, NG6 Valve, 12VDC, Wiring Box ¹
	5	CETOP3 (D03, NG6) Interface, No Valve ¹
	6	CETOP3, NG6 Valve, 24VDC with Hirschmann Connector ¹
	7	CETOP3, NG6 Valve, 110VAC/50Hz with Hirschmann Connector ¹
5A	0	With Deadband ¹
	1	Without Deadband ¹
8A	0	75-250 PSI (5-17 Bar)
	1	250-450 PSI (17-31 Bar)
9A	0	24VDC ¹
	1	12VDC ¹
All Other	0	None
Motor	Code	Reduced Displacement
M*F M*G M*M M*N	0	Standard Cam (19°)
	1	M6 with 17° Cam – 5.3 in ³ /rev (87cc/rev) M7 with 17° Cam – 6.4 in ³ /rev (105 cc/rev) M8 with 17° Cam – 7.1 in ³ /rev (116 cc/rev) M11 with 17° Cam – 9.7 in ³ /rev (160 cc/rev) M14 with 17° Cam – 12.5 in ³ /rev (205 cc/rev) M24 with 17° Cam – 22.0 in ³ /rev (360 cc/rev) M30 with 17° Cam – 27.2 in ³ /rev (446 cc/rev)
	2	M6 with 15° Cam – 4.6 in ³ /rev (76 cc/rev) M7 with 15° Cam – 5.6 in ³ /rev (92 cc/rev) M8 with 15° Cam – 6.2 in ³ /rev (102 cc/rev) M11 with 15° Cam – 8.5 in ³ /rev (140 cc/rev) M14 with 15° Cam – 10.9 in ³ /rev (179 cc/rev)
	3	M6 with 13° Cam – 4.0 in ³ /rev (66 cc/rev) M7 with 13° Cam – 4.8 in ³ /rev (79 cc/rev) M8 with 13° Cam – 5.3 in ³ /rev (88 cc/rev)

Code	Shuttle Valve Features
Omit	M*F/M/V/R Motors only
0	Without Orifices
2	With Orifices

Code	External Drive
Omit	None (M*F/G/V/H units only)
A	SAE-A (SAE 82-2) – M6, 7, 8, 11, 14M/N/R/L only
B	SAE-B (SAE 101-2) – M6, 7, 8M/N/R/L SAE-B (SAE 101-2 & 101-4) – M11, 14, 24, 30M/N/R/L
C	SAE-C (SAE 127-2) – M6, 7, 8M/N/R/L SAE-C (SAE 127-2 & 127-4) – M11, 14, 24, 30M/N/R/L
D	SAE-D (SAE 152-4) – M11, 14, 24, 30M/N/R/L only
E	SAE-E (SAE 165-4) – M11, 14, 24, 30M/N/R/L only
F	SAE-F (SAE 177-4) – M24, 30M/N/R/L only
M	Blanking Plate-less Coupling

Code	External Mounting
0	No External Motor Mounted
1	External Motor Mounted (must be separately specified) – Requires Special Modification “-M2”
2	ATEX Externally Mounted Motor

Code	Special Modifications
Omit	None
NP	No Paint
M2	Other Special Modification (example: bronze caged barrel bearing for low viscosity fluids, tandem motors, etc.)
EX	ATEX APPROVED (May contain additional modifications. Contact tech support.)

= Omit if not required

**Section A
Input Shaft
and Retainer**

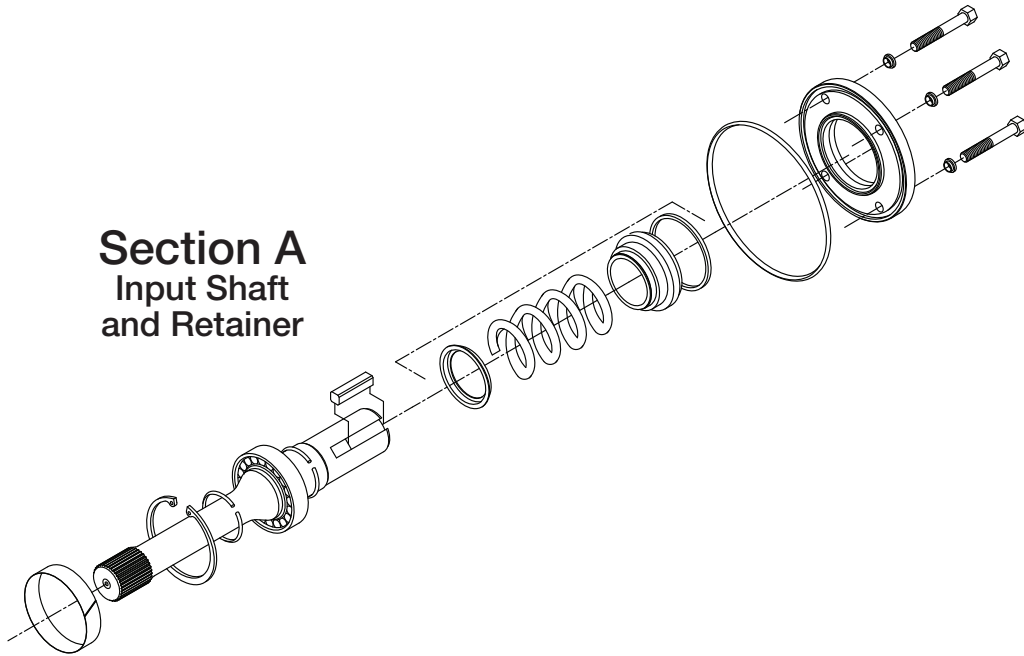

**Section B
Housing and
Barrel Bearing**

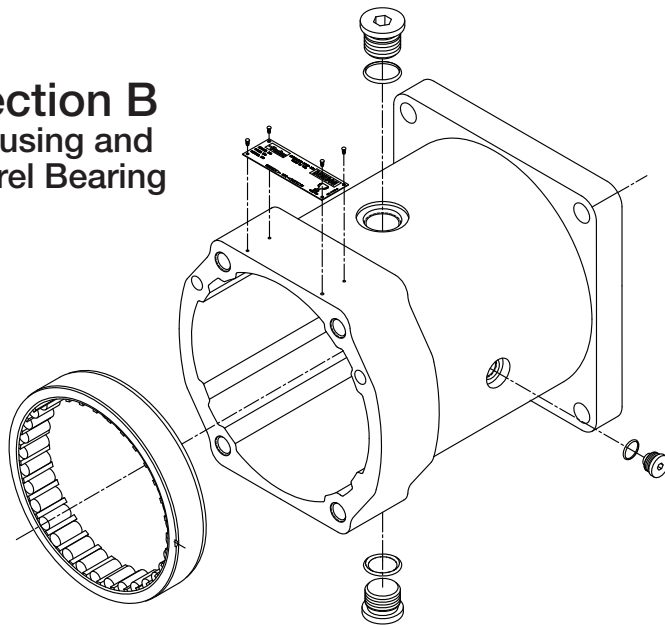

Section C
Rotating Group

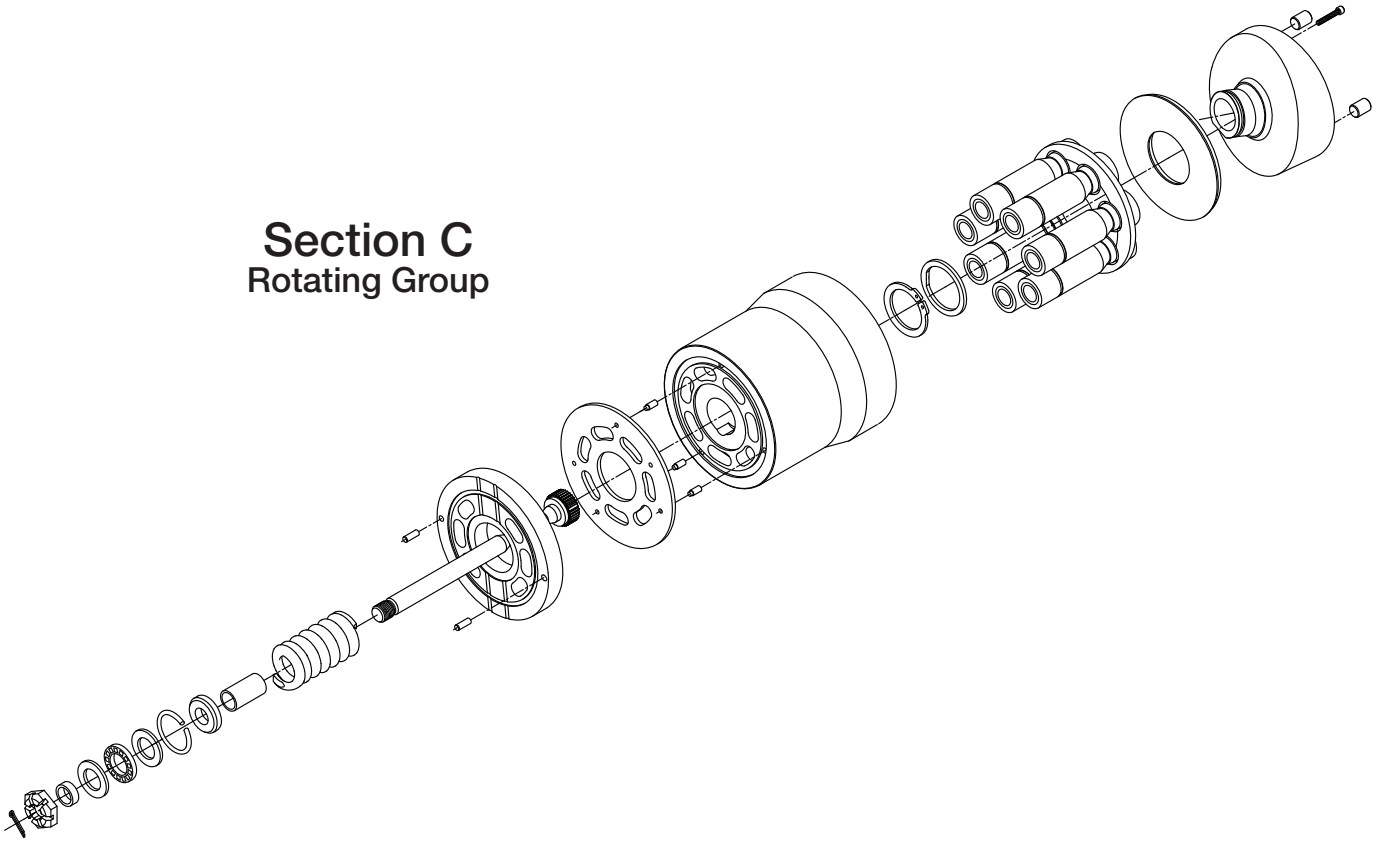

Section D
Port Block

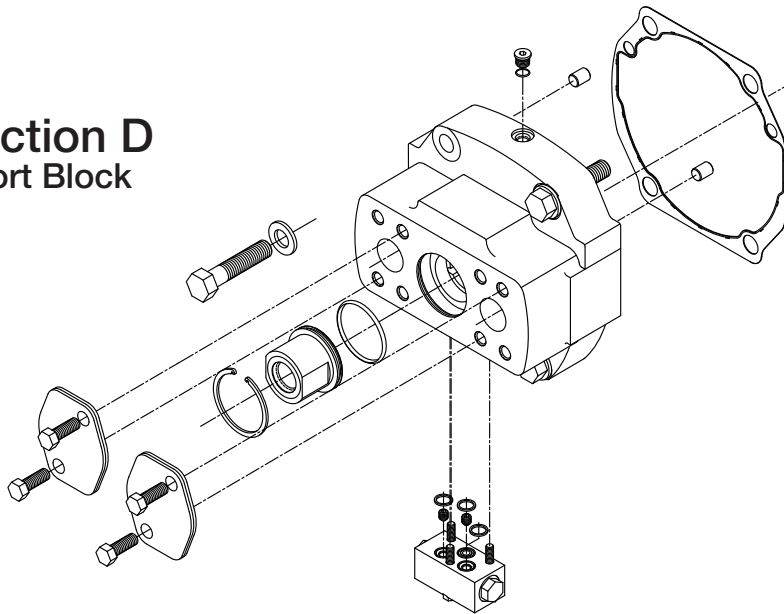

**Section A
Input Shaft
and Retainer**

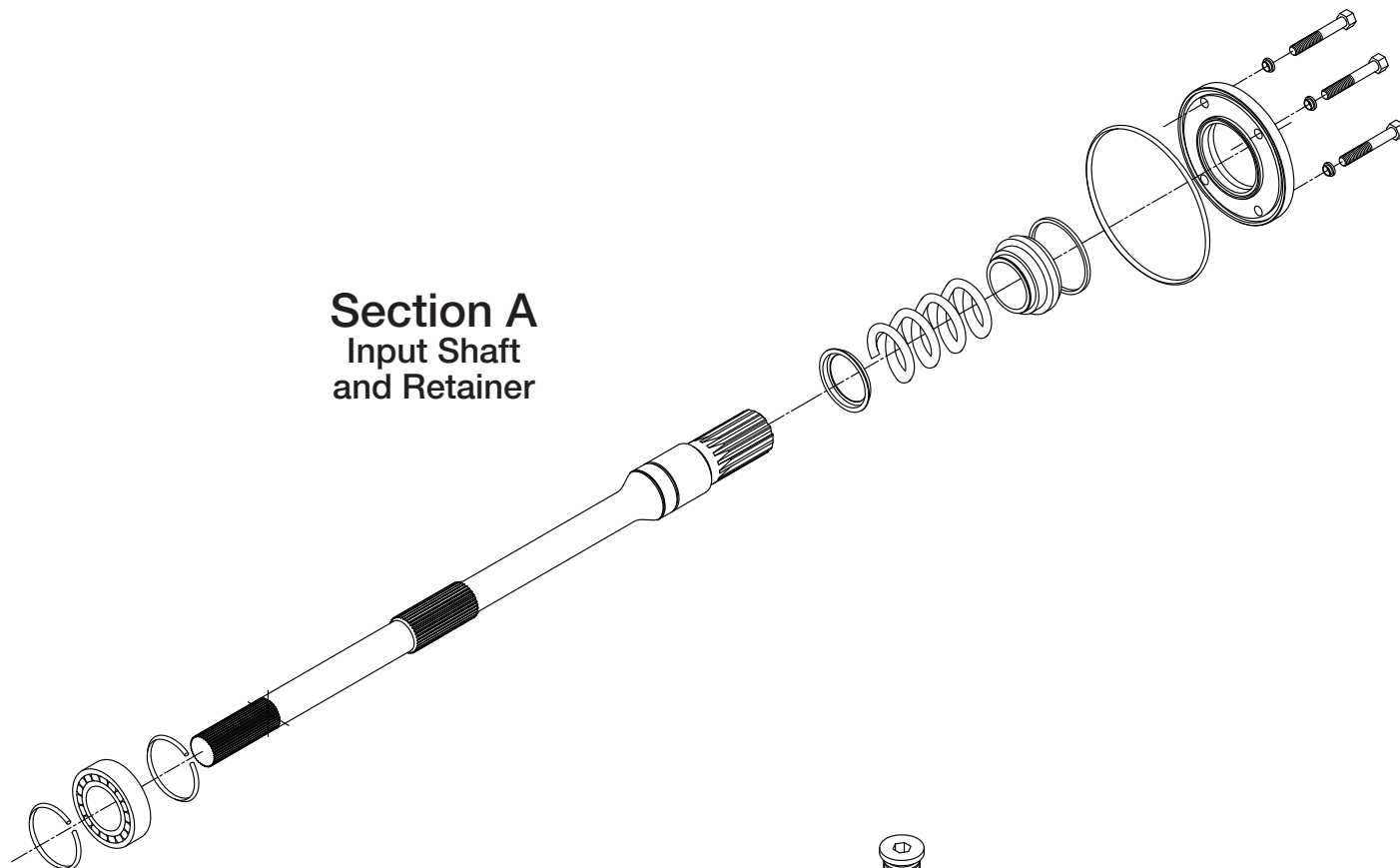

**Section B
Housing and
Barrel Bearing**

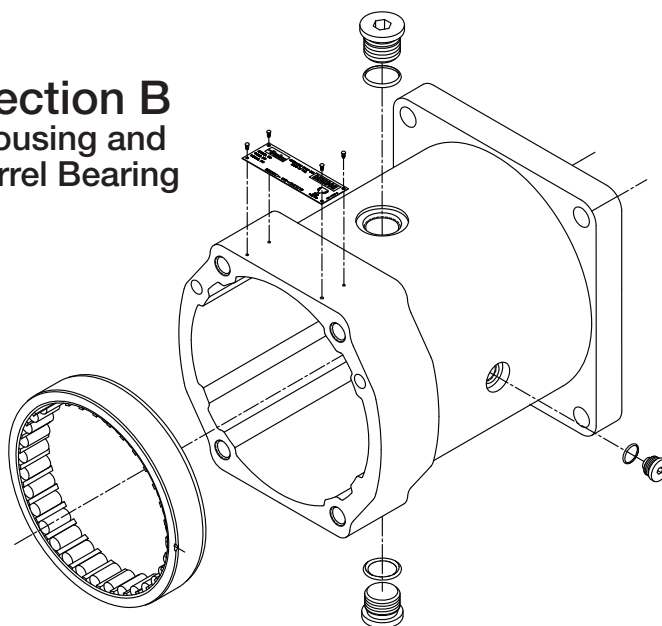

Section C
Rotating Group

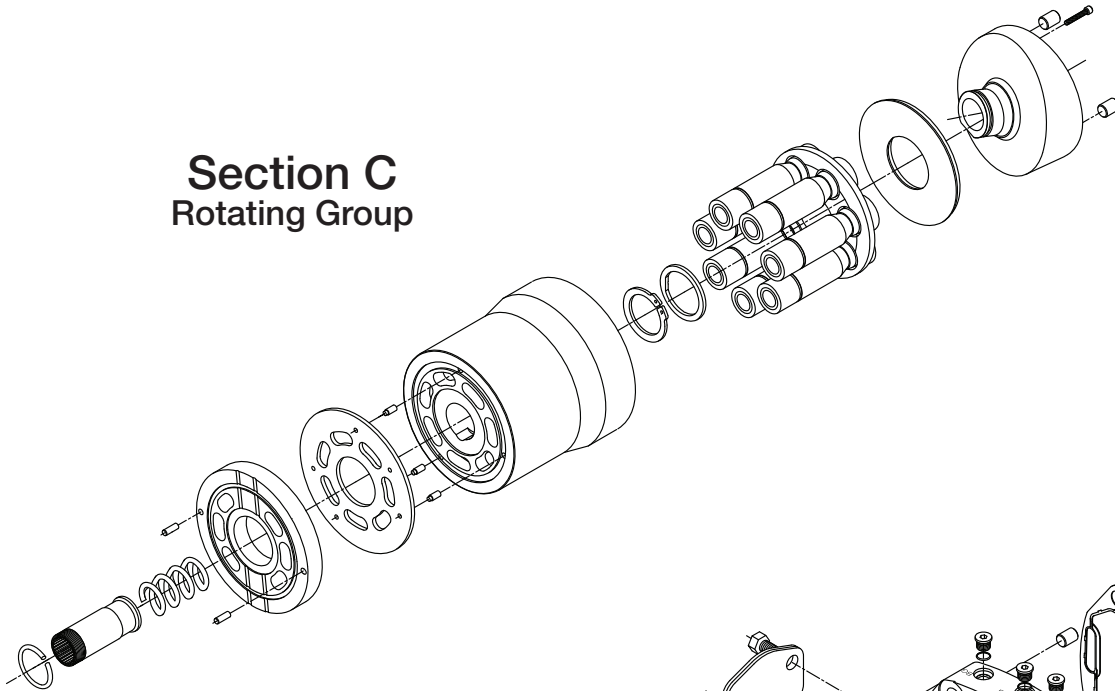

Section D
Port Block

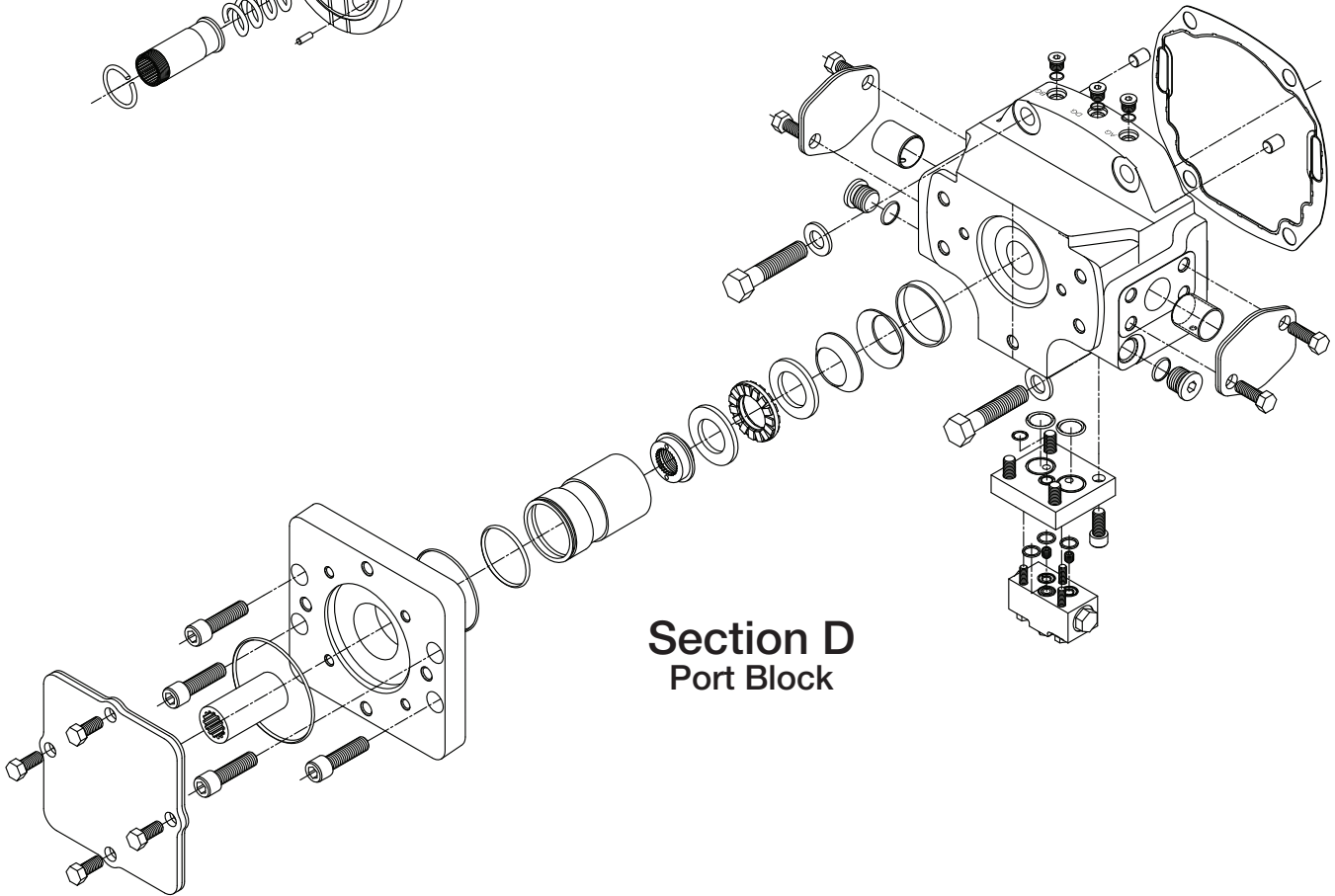

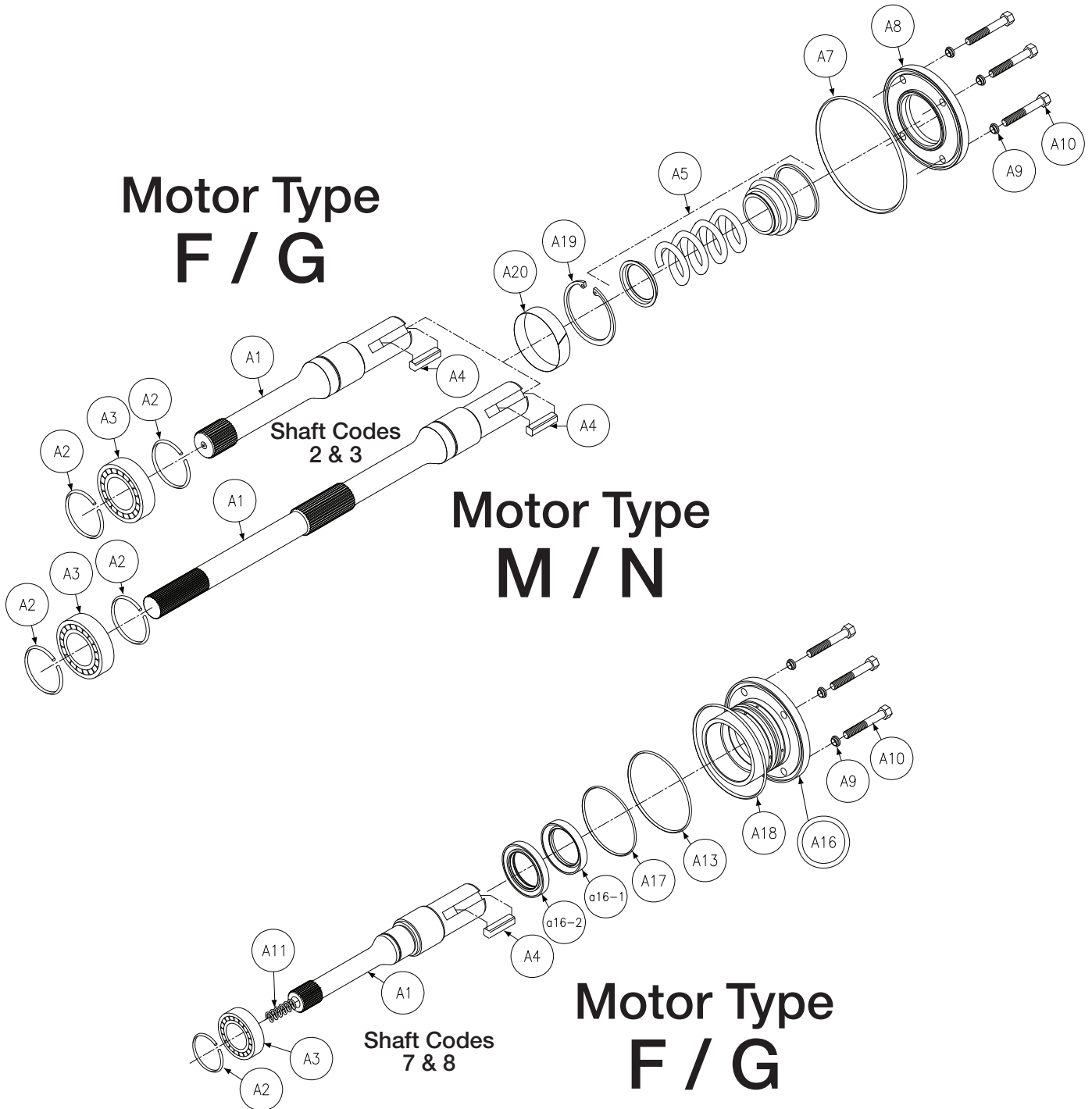

Section A						
M11/14 Motor Type F/G/M/N - Input Shaft and Seal Retainer Assembly						
Balloon #	Motor Type	Shaft Code	Seal Code	Item #	Description	Qty
A1	M 11/14 F & G	2	**	033-71552-0	Shaft, Keyed SAE E, Mech Shaft Seal, No Rear Drive	1
	M 11/14 F & G	3	**	033-71572-0	Shaft, Splined SAE E, Mech Shaft Seal, No Rear Drive	
	M 11/14 F & G	7	**	033-93883-0	Shaft, Keyed SAE E, Double Lip Seal, No Rear Drive	
	M 11/14 F & G	8	**	033-94170-0	Shaft, Splined SAE E, Double Lip Seal, No Rear Drive	
	M 11/14 M & N	2	**	033-93513-0	Shaft, Keyed SAE E, Mech Shaft Seal, With Rear Drive	
	M 11/14 M & N	3	**	033-93064-0	Shaft, Splined SAE E, Mech Shaft Seal, With Rear Drive	
A2	M 11/14 F / G / M / N	2/3	**	033-71641-0	Ring, Retaining	2
	M 11/14 F / G	7/8	**	033-59504-0		1
A3	M 11/14 F / G / M / N	2/3	**	230-82148-0	Bearing, Shaft	1
	M 11/14 F / G	7/8	**	230-82214-0		
A4	M 11/14 F / G / M / N	2/7	**	033-71514-0	Key, Shaft Drive	1
A5	M 11/14 F / G / M / N	2/3	1	623-00016-0	Seal, Shaft Mechanical	1
	M 11/14 F / G / M / N		4	623-00016-4		
	M 11/14 F / G / M / N		5	623-00016-5		
A7	M 11/14 F / G / M / N	2/3	1	671-00249-0	Gasket O-ring	1
	M 11/14 F / G / M / N	2/3	4	674-00249-0		
	M 11/14 F / G / M / N	2/3	5	675-00249-0		
A8	M 11/14 F / G / M / N	2/3	**	033-57872-0	Retainer - Seal, For Mech Shaft Seal	1
A9	M 11/14 F / G / M / N	2/3/7/8	**	631-45007-0	Washer, Nylitite	4
A10	M 11/14 F / G / M / N	2/3/7/8	**	306-40021-0	Screw, HHC 3/8-16 UNC X 2 1/4	4
A11	M 11/14 F / G	7/8	**	033-91713-0	Spring, Bearing pre-load	1
A13	M 11/14 F / G	7/8	1	671-00044-0	Gasket O-ring	1
	M 11/14 F / G	7/8	4	674-00044-0		
	M 11/14 F / G	7/8	5	675-00044-0		
A16	M 11/14 F / G	7/8		033-91709-0	Retainer - Seal, For Double Lip Seals	1
a16-1	M 11/14 F / G	7/8	**	620-82101-0	Shaft, Seal Outer, Secondary	1
a16-2	M 11/14 F / G	7/8	**	620-82113-0	Shaft, Seal Inner, Primary	1
A17	M 11/14 F / G	7/8	1	671-00237-0	Gasket O-ring	1
	M 11/14 F / G	7/8	4	674-00237-0		
	M 11/14 F / G	7/8	5	675-00237-0		
A18	M 11/14 F / G	7/8	1	671-00251-0	Gasket O-ring	1
	M 11/14 F / G	7/8	4	674-00251-0		
	M 11/14 F / G	7/8	5	675-00251-0		
A19	M 11/14 F / G / M / N	2/3	**	356-65013-0	Ring, Retaining	1
A20	M 11/14 F / G / M / N	2/3	**	037-53983-0	Shim, 11/14 .008 inches nonimal thickness.	Select fit 1 only
	M 11/14 F / G / M / N	2/3	**	033-53984-0	Shim, 11/14 .007 inches nonimal thickness	



Seal Kits contain all seals for the following:			
1. Main Motor - With or Without a Shuttle Valve			
2. Shaft Seal			
Shaft Code	Motor	Seal Code	Part Number
2/3	M 11/14 F / G	1	S23-00143-0
2/3	M 11/14 F / G	4	S23-00143-4
2/3	M 11/14 F / G	5	S23-00143-5
7/8	M 11/14 F / G	1	S23-19636-0
7/8	M 11/14 F / G	4	S23-19636-4
7/8	M 11/14 F / G	5	S23-19636-5
2/3	M 11/14 M / N	1	S23-19635-0
2/3	M 11/14 M / N	4	S23-19635-4
2/3	M 11/14 M / N	5	S23-19635-5
7/8	M 11/14 M / N	1	N/A
7/8	M 11/14 M / N	4	N/A
7/8	M 11/14 M / N	5	N/A

Shaft & Bearing Assembly Kit			
Contain Items A1, A2, A3, & A4 as applicable			
Shaft Code	Motor	Seal Code	Part Number
2	M 11/14 F / G	**	S13-44180-0
3	M 11/14 F / G	**	S13-44181-0
7	M 11/14 F / G	**	S23-17891-0
8	M 11/14 F / G	**	S23-18177-0
2	M 11/14 M & N	**	S23-17312-0
3	M 11/14 M & N	**	S23-16716-0

Seal Retainer Assembly Kit for Shaft Codes 7/8			
Contain Items A16, a16-1, & a16-2			
Shaft Code	Motor	Seal Code	Part Number
7/8	M 11/14 F / G	**	S23-15931-0

Motor Type F / G / N / M

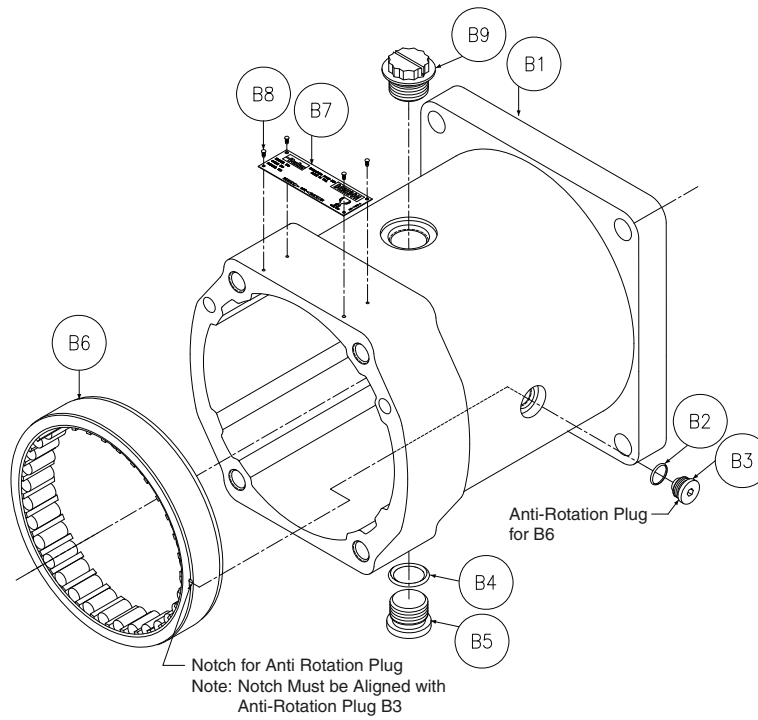

Section View - B - Housing and Barrel Bearing Assembly

Section B						
M11/14 Motor Type F/G/M/N - Housing, Cam, and Barrel Bearing Assembly						
Balloon #	Motor Type	Shaft Code	Seal Code	Item #	Description	Qty
B1	M 11/14 F/G/M/N	2/3	**	033-91192-0	Housing, Fixed Displacement	1
	M 11/14 F/G/M/N	7/8	**	033-94169-0		
B2	M 11/14 F/G/M/N	2/3/7/8	1	691-00908-0	Gasket, O-ring	1
	M 11/14 F/G/M/N	2/3/7/8	4	694-00908-0		
	M 11/14 F/G/M/N	2/3/7/8	5	695-00908-0		
B3	M 11/14 F/G/M/N	2/3/7/8	**	033-91106-0	Plug, Anti-Rotation Barrel Bearing	1
B4	M 11/14 F/G/M/N	2/3/7/8	1	691-00916-0	Gasket, O-ring	2
	M 11/14 F/G/M/N	2/3/7/8	4	694-00916-0		
	M 11/14 F/G/M/N	2/3/7/8	5	695-00916-0		
B5	M 11/14 F/G/M/N	2/3/7/8	**	488-35024-0	Plug, Socket Head SAE - 16	2
B6	M 11/14 F/G/M/N	2/3/7/8	**	033-91190-0	Bearing, Barrel	1
B7	M 11/14 F/G/M/N	2/3/7/8	**	033-71908-0	Tag, Name	1
B8	M 11/14 F/G/M/N	2/3/7/8	**	320-10203-0	Screw, Drive	4
B9	M 11/14 F/G/M/N	2/3/7/8	**	449-00019-0	Plug, Shipping	1

Housing Assembly		
The Following Kits contain items B1, B2, B3, B4, B5, and B6		
Shaft Code	Motor Type	Part Number
2/3	M 11/14 F/G/M/N	S13-43964-0
7/8	M 11/14 F/G/M/N	S23-18176-0



Motor Type F / G

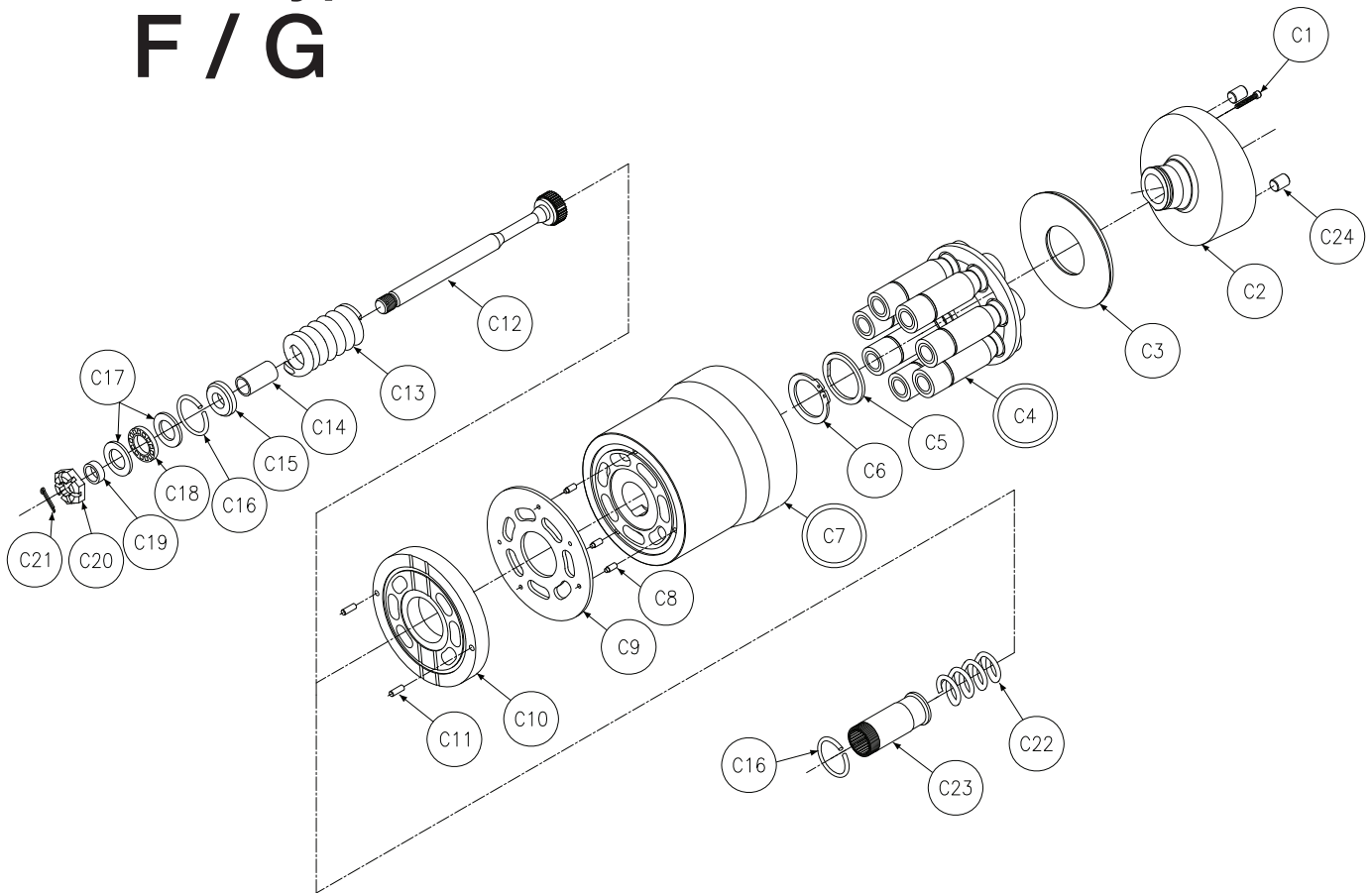

Motor Type M / N

Section C							
M11/14 Motor Type F/G/M/N Rotating Group, Cam and Holddown Assembly							
Balloon #	Motor Type	Displacement	Shaft Code	Cam Angle	Item #	Description	Qty
C1	M 11/14 F/G/M/N	**	2/3/7/8	**	358-10180-0	Screw, SHC 10-24 UNC X 1 1/4	1
C2	M 11 F/G/M/N	11.0 in3/rev (180CC/rev)	2/3	19 Degrees	033-57880-0	Cam, Fixed Displacement	1
	M 11 F/G/M/N	9.7 in3/rev (160CC/rev)	2/3	17 Degrees	033-53990-0		
	M 11 F/G/M/N	8.5 in3/rev (140CC/rev)	2/3	15 Degrees	033-92114-0		
	M 14 F/G/M/N	14.0 in3/rev (229CC/rev)	2/3	19 Degrees	033-57880-0		
	M 14 F/G/M/N	12.5 in3/rev (205CC/rev)	2/3	17 Degrees	033-53990-0		
	M 14 F/G/M/N	10.9 in3/rev (179 CC/rev)	2/3	15 Degrees	033-92114-0		
	M 11 F/G/M/N	11.0 in3/rev (180CC/rev)	7/8	19 Degrees	033-94168-0		
	M 14 F/G/M/N	14.0 in3/rev (229CC/rev)	7/8	19 Degrees	033-94168-0		
C3	M 11/14 F/G/M/N	**	2/3/7/8	**	033-71569-0	Creep, Plate	1
C4	M 11 F/G/M/N	11.0 in3/rev (180CC/rev)	2/3/7/8	**	S13-45544-0	Piston, Shoe, & Retainer Assy	1
	M 14 F/G/M/N	14.0 in3/rev (229CC/rev)	2/3/7/8	**	S13-43970-0		
C5	M 11/14 F/G/M/N	**	2/3/7/8	**	033-91706-0	Thrust Washer	1
C6	M 11/14 F/G/M/N	**	2/3/7/8	**	033-71556-0	Ring, Ret.-.109/.107 (2,74mm) Thk - Yellow	Select Fit 1 only
	M 11/14 F/G/M/N	**	2/3/7/8	**	033-71557-0	Ring, Ret.-.105/.107 (2,69mm) Thk - Green	
	M 11/14 F/G/M/N	**	2/3/7/8	**	033-71558-0	Ring, Ret.-.103/.105 (2,64mm) Thk - Red	
	M 11/14 F/G/M/N	**	2/3/7/8	**	033-71559-0	Ring, Ret.-.101/.103 (2,59mm) Thk - Blue	
	M 11/14 F/G/M/N	**	2/3/7/8	**	033-91231-0	Ring, Ret.-.098/.100 (2,51mm) Thk - White	
C7	M 11 F/G/M/N	11.0 in3/rev (180CC/rev)	2/3/7/8	**	S13-45381-0	Cylinder Barrel	1
	M 14 F/G/M/N	14.0 in3/rev (229CC/rev)	2/3/7/8	**	S13-43965-0		
C8	M 11/14 F/G/M/N	**	2/3/7/8	**	033-49825-0	Pin, Face Plate	3
C9	M 11 F/G/M/N	11.0 in3/rev (180CC/rev)	2/3/7/8	**	033-71921-0	Plate, Face	1
	M 14 F/G/M/N	14.0 in3/rev (229CC/rev)	2/3/7/8	**	033-71575-0		
C10	M 11 F/G/M/N	11.0 in3/rev (180CC/rev)	2/3/7/8	**	033-71916-0	Plate, Port	1
	M 14 F/G/M/N	14.0 in3/rev (229CC/rev)	2/3/7/8	**	033-71551-0		
C11	M 11/14 F/G/M/N	**	2/3/7/8	**	324-21610-0	Pin, Dowel - Port Plate	2
C12	M 11/14 F/G	**	2/3/7/8	**	033-71573-0	Shaft, Aux holddown	1
C13	M 11/14 F/G	**	2/3/7/8	**	033-71562-0	Spring, Barrel Hold- down	1
C14	M 11/14 F/G	**	2/3/7/8	**	033-71561-0	Stop, Barrel Holddown	1
C15	M 11/14 F/G	**	2/3/7/8	**	033-71560-0	Retainer, Spring	1
C16	M 11/14 F/G/M/N	**	2/3/7/8	**	033-71564-0	Ring, Retaining	1
C17	M 11/14 F/G	**	2/3/7/8	**	350-10081-0	Washer, Thrust	2
C18	M 11/14 F/G	**	2/3/7/8	**	230-82164-0	Bearing, Thrust	1
C19	M 11/14 F/G	**	2/3/7/8	**	033-72101-0	Seal, Ring	1
C20	M 11/14 F/G	**	2/3/7/8	**	033-72026-0	Nut, Holddown	1
C21	M 11/14 F/G	**	2/3/7/8	**	322-03324-0	Pin, Cotter	1
C22	M11/14 M/N	**	2/3/7/8	**	033-92686-0	Spring, Pre-load	1
C23	M11/14 M/N	**	2/3/7/8	**	033-92687-0	Sleeve, Barrel Hold- down	1
C24	M 11/14 F/G/M/N	**	2/3/7/8	**	324-23216-0	Pin, Dowel	2



Rotating Group Kit "Major"			
The following Kits contain C3, C4, C7, C8, C9, C10, C11 and (Barrel Bearing) item B6			
Shaft Code	Motor Type	Displacement	Part Number
2/3/7/8	M 11 F/G/M/N	11.0 in ³ /rev (180CC/rev)	S23-17109-0
2/3/7/8	M 14 F/G/M/N	14.0 in ³ /rev (229CC/rev)	S23-17110-0

Rotating Group Kit "Minor"			
The following Kits contain C3, C4, C8, C9, C10, and C11			
Shaft Code	Motor Type	Displacement	Part Number
2/3/7/8	M 11 F/G/M/N	11.0 in ³ /rev (180CC/rev)	S23-17427-0
2/3/7/8	M 14 F/G/M/N	14.0 in ³ /rev (229CC/rev)	S23-17428-0

Retaining Ring Kit for Piston Shoe Holddown			
This Service Kit contains one each of all part numbers in C6			
However, Individual Multiple Piece kits, (5 piece kits), are also available. See Below			
Shaft Code	Motor Type	Seal Code	Part Number
2/3/7/8	M 11/14 F/G/M/N	**	S23-12547-0

Retaining Ring Multiple Pack Kits for Shoe Holddown , (5 pieces each)			
Shaft Code	Motor Type	QTY	Part Number
2/3/7/8	M 11/14 F/G/M/N	5 Pieces	033-71556-0K
2/3/7/8	M 11/14 F/G/M/N	5 Pieces	033-71557-0K
2/3/7/8	M 11/14 F/G/M/N	5 Pieces	033-71558-0K
2/3/7/8	M 11/14 F/G/M/N	5 Pieces	033-71559-0K
2/3/7/8	M 11/14 F/G/M/N	5 Pieces	033-91231-0K

Motor Type F / G

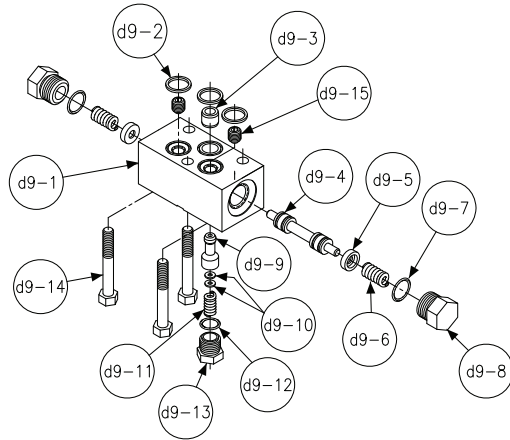
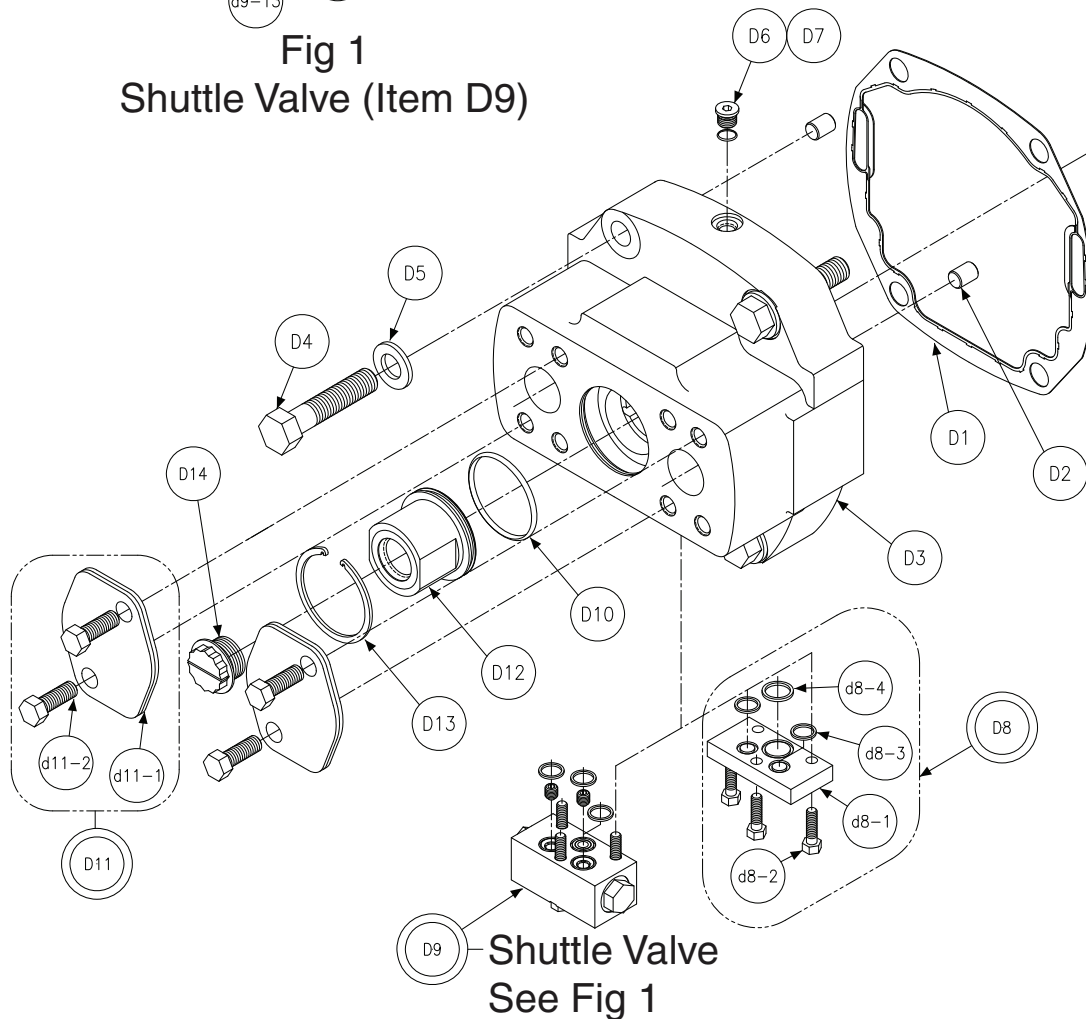

Fig 1
Shuttle Valve (Item D9)



Section D						
M11/14 Motor Type F & G Port Block Assembly						
Balloon #	Motor Type	Shaft Code	Seal Code	Item #	Description	Qty
D1	M 11/14 F/G/M/N	2/3/7/8	**	033-91171-0	Gasket, Port Block	1
D2	M 11/14 F/G/M/N	2/3/7/8	**	033-70509-0	Pin, Dowel	2
D3	M 11/14 F/G	2/3/7/8	**	033-53847-0	Block, Port, With Shuttle Pad	1
D4	M 11/14 F/G	2/3/7/8	**	306-40024-0	Screw, HHC 3/4-10 UNC X 3 1/2	4
D5	M 11/14 F/G	2/3/7/8	**	350-10109-0	Washer, Plain	4
D6	M 11/14 F/G	2/3/7/8	1	691-00906-0	Gasket O-ring	1
	M 11/14 F/G	2/3/7/8	4	694-00906-0		
	M 11/14 F/G	2/3/7/8	5	695-00906-0		
D7	M 11/14 F/G	2/3/7/8	**	488-35014-0	Plug, Hex Socket SAE-6	1
D8	M 11/14 F	2/3/7/8	**	See Kit P/N below	Blanking Plate Assy, Shuttle	
d8-1	M 11/14 F	2/3/7/8	**	033-71649-0	Plate, Blanking	1
d8-2	M 11/14 F	2/3/7/8	**	306-40071-0	SCREW, HHC 5/16-18 UNC X 1 LG	3
d8-3	M 11/14 F	2/3/7/8	1	691-10014-0	Gasket, Tetraseal	2
	M 11/14 F	2/3/7/8	4	694-10014-0		
	M 11/14 F	2/3/7/8	5	695-10014-0		
d8-4	M 11/14 F	2/3/7/8	1	691-10019-0	Gasket, Tetraseal	1
	M 11/14 F	2/3/7/8	4	694-10019-0		
	M 11/14 F	2/3/7/8	5	695-10019-0		
D9	M 11/14 G	2/3/7/8	**	See Kit P/N below	Shuttle, Hot Oil without orifices	
	M 11/14 G	2/3/7/8	**	See Kit P/N below	Shuttle, Hot Oil with .078 orifices	
d9-1	M 11/14 G	2/3/7/8	**	033-53117-0	Body, Shuttle	1
d9-2	M 11/14 G	2/3/7/8	1	691-10016-0	Gasket O-ring	3
	M 11/14 G	2/3/7/8	4	694-10016-0		
	M 11/14 G	2/3/7/8	5	695-10016-0		
d9-3	M 11/14 G	2/3/7/8	**	033-53154-0	Seat	1
d9-4	M 11/14 G	2/3/7/8	**	033-70529-0	Spool	1
d9-5	M 11/14 G	2/3/7/8	**	033-70495-0	Washer	2
d9-6	M 11/14 G	2/3/7/8	**	033-70515-0	Spring	2
d9-7	M 11/14 G	2/3/7/8	1	691-00908-0	Gasket O-ring	2
	M 11/14 G	2/3/7/8	4	694-00908-0		
	M 11/14 G	2/3/7/8	5	695-00908-0		
d9-8	M 11/14 G	2/3/7/8	**	033-93510-0	Plug	2
d9-9	M 11/14 G	2/3/7/8	**	033-71925-0	Spool	1
d9-10	M 11/14 G	2/3/7/8	**	345-20004-0	Shim, Washer	2
d9-11	M 11/14 G	2/3/7/8	**	033-71923-0	Spring	1
d9-12	M 11/14 G	2/3/7/8	1	691-00906-0	Gasket O-ring	1
	M 11/14 G	2/3/7/8	4	694-00906-0		
	M 11/14 G	2/3/7/8	5	695-00906-0		
d9-13	M 11/14 G	2/3/7/8	**	033-72129-0	Plug	1
d9-14	M 11/14 G	2/3/7/8	**	306-40106-0	Screw, HHC, 5/16-18 UNC X 2	3
d9-15	M 11/14 G	2/3/7/8	**	033-53523-0	Screw, Orifice .078 inch Dia.	2
D10	M 11/14 F/G	2/3/7/8	1	671-00147-0	Gasket O-ring	1
	M 11/14 F/G	2/3/7/8	4	674-00147-0		
	M 11/14 F/G	2/3/7/8	5	675-00147-0		
D11	M 11/14 F/G	2/3/7/8	**	See Kit P/N Below	Cover, Port-Shipping Assembly	
d11-1	M 11/14 F/G	2/3/7/8	**	033-71083-0	Cover, Port- Shipping	2
d11-2	M 11/14 F/G	2/3/7/8	**	306-24160-0	Screw, HHC	4
D12	M 11/14 F/G	2/3/7/8	**	033-72100-0	Cover, End Port	1
D13	M 11/14 F/G	2/3/7/8	**	356-65082-0	Ring, Retaining	1
D14	M 11/14 F/G	2/3/7/8	**	449-00019-0	Plug, Shipping	1



Blanking Plate, Shuttle		
The following Kit contain items d8-1 thru d8-4		
Shaft Code	Motor Type	Part Number
2/3/7/8	M 11/14 F	S23-00181-0

Shuttle Assembly Kit (without orifices)		
The following Kit contain items d9-1 thru d9-14		
Shaft Code	Motor Type	Part Number
2/3/7/8	M 11/14 G	S13-48273-0

Shuttle Assembly Kit (with .078 orifices)		
The following Kit contain items d9-1 thru d9-15		
Shaft Code	Motor Type	Part Number
2/3/7/8	M 11/14 G	S13-48776-0

Cover, Port Shipping Kit		
The following Kit contain items d11-1 and d11-2		
Shaft Code	Motor Type	Part Number
2/3/7/8	M 11/14 F/G/M/N	S13-26133-0

Motor Type M / N

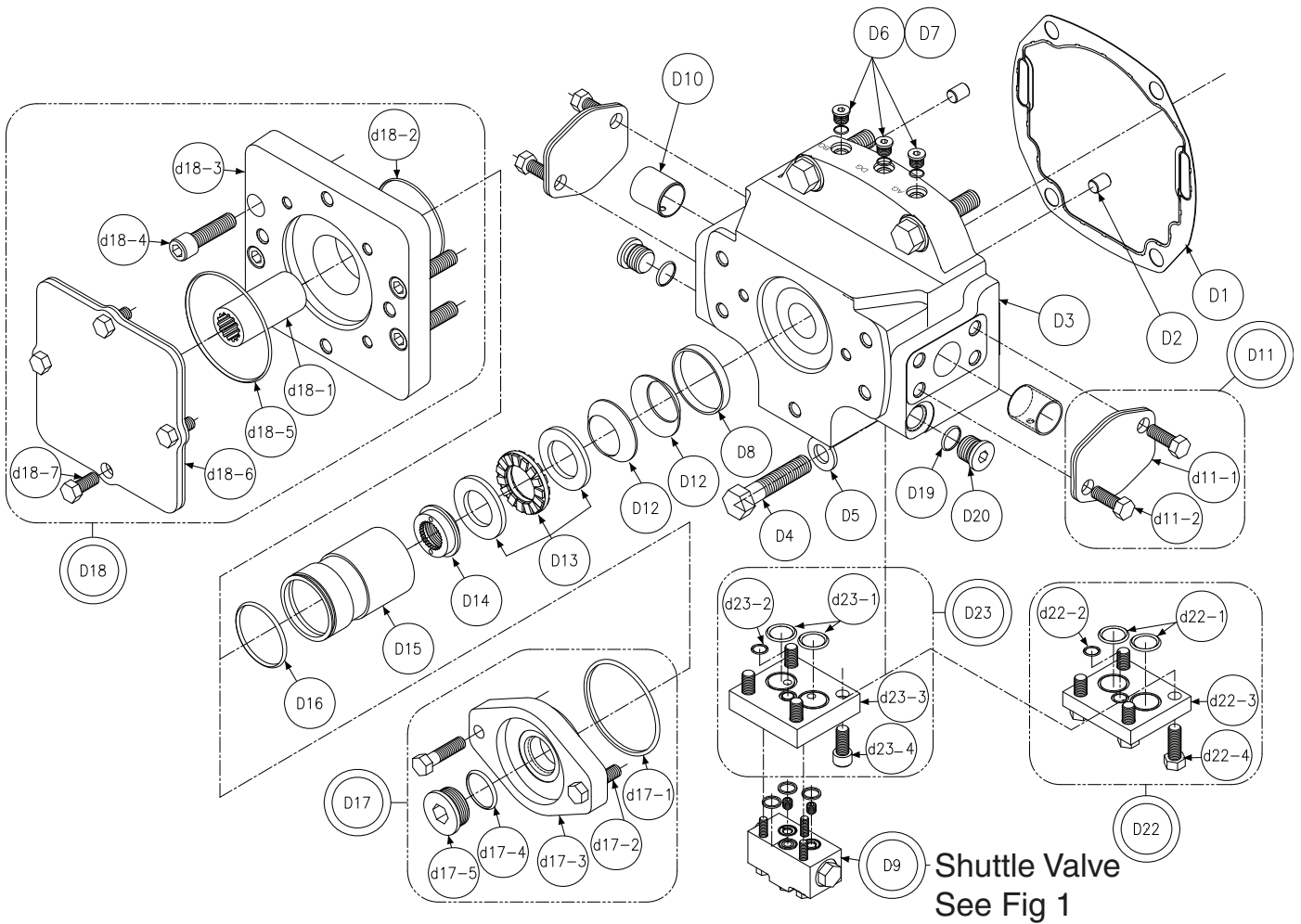

Section View - D - Motor Type M & N Port Block Assembly

M11/14 Motor Type M & N Port Block Assembly						
Balloon #	Motor Type	Shaft Code	Seal Code	Item #	Description	Qty
D1	M 11/14 M/N	2/3/7/8	**	033-91171-0	Gasket, Port Block	1
D2	M 11/14 M/N	2/3/7/8	**	033-70509-0	Pin, Dowel	2
D3	M 11/14 M/N	2/3/4/5	**	033-93065-0	Block, Port, With Shuttle Pad	1
D4	M 11/14 M/N	2/3/7/8	**	306-40024-0	Screw, HHC 3/4-10 UNC X 3 1/2	4
D5	M 11/14 M/N	2/3/7/8	**	350-10109-0	Washer, Plain	4
D6	M 11/14 M/N	2/3/7/8	1	691-00906-0	Gasket O-ring	3
	M 11/14 M/N	2/3/7/8	4	694-00906-0		
	M 11/14 M/N	2/3/7/8	5	695-00906-0		
D7	M 11/14 M/N	2/3/7/8	**	488-35041-0	Plug, Hex Socket SAE-6	3
D8	M 11/14 M/N	2/3/7/8	**	033-92688-0	Locator, Spring Disc	1
D9	M 11/14 N	2/3/7/8	**	See Kit P/N below	Shuttle, Hot Oil without orifices	
	M 11/14 N	2/3/7/8	**	See Kit P/N below	Shuttle, Hot Oil with .078 orifices	
d9-1	M 11/14 N	2/3/7/8	**	033-53117-0	Body, Shuttle	1
d9-2	M 11/14 N	2/3/7/8	1	691-10016-0	Gasket O-ring	3
	M 11/14 N	2/3/7/8	4	694-10016-0		
	M 11/14 N	2/3/7/8	5	695-10016-0		
d9-3	M 11/14 N	2/3/7/8	**	033-53154-0	Seat	1
d9-4	M 11/14 N	2/3/7/8	**	033-70529-0	Spool	1
d9-5	M 11/14 N	2/3/7/8	**	033-70495-0	Washer	2
d9-6	M 11/14 N	2/3/7/8	**	033-70515-0	Spring	2
d9-7	M 11/14 N	2/3/7/8	1	691-00908-0	Gasket O-ring	2
	M 11/14 N	2/3/7/8	4	694-00908-0		
	M 11/14 N	2/3/7/8	5	695-00908-0		
d9-8	M 11/14 N	2/3/7/8	**	033-93510-0	Plug	2
d9-9	M 11/14 N	2/3/7/8	**	033-71925-0	Spool	1
d9-10	M 11/14 N	2/3/7/8	**	345-20004-0	Shim, Washer	2
d9-11	M 11/14 N	2/3/7/8	**	033-71923-0	Spring	1
d9-12	M 11/14 N	2/3/7/8	1	691-00906-0	Gasket O-ring	1
	M 11/14 N	2/3/7/8	4	694-00906-0		
	M 11/14 N	2/3/7/8	5	695-00906-0		
d9-13	M 11/14 N	2/3/7/8	**	033-72129-0	Plug	1
d9-14	M 11/14 N	2/3/7/8	**	306-40106-0	Screw, HHC, 5/16-18 UNC X 2	3
d9-15	M 11/14 N	2/3/7/8	**	033-53523-0	Screw, Orifice .078 inch Dia.	2
D10	M 11/14 M/N	2/3/7/8	**	033-57893-0	Sleeve, Solid 1-1/2 in	2
D11	M 11/14 M/N	2/3/7/8	**	See Kit P/N below	Cover, Port-Shipping Assembly	
d11-1	M 11/14 M/N	2/3/7/8	**	033-71083-0	Cover, Port- Shipping	2
d11-2	M 11/14 M/N	2/3/7/8	**	306-24160-0	Screw, HHC	4
D12	M 11/14 M/N	2/3/7/8	**	033-92689-0	Spring, Disc-Holddown	2
D13	M 11/14 M/N	2/3/7/8	**	230-82222-0	Bearing & Washer ass'y, Thrust	1
D14	M 11/14 M/N	2/3/7/8	**	033-92690-0	Nut, Holddown	1
D15	M 11/14 M/N	2/3/7/8	**	033-92691-0	Sleeve, Repl Isolation	1
D16	M 11/14 M/N	2/3/7/8	1	671-00147-0	Gasket O-ring	1
	M 11/14 M/N	2/3/7/8	4	674-00147-0		
	M 11/14 M/N	2/3/7/8	5	675-00147-0		
M11/14 Motor Type M & N Port Block Assembly (Continued)						
Balloon #	Motor Type	Shaft Code	Seal Code	Item #	Description	Qty

Continued on next page.



D17	M 11/14 M/N	2/3/7/8	**	See Kit P/N Below	Cover Assy, Operational Hard Cover Adapter Kit SAE B	
d17-1	M 11/14 M/N	2/3/7/8	1	671-00155-0	Gasket, O-ring	1
	M 11/14 M/N	2/3/7/8	4	674-00155-0		
	M 11/14 M/N	2/3/7/8	5	675-00155-0		
d17-2	M 11/14 M/N	2/3/7/8	**	306-40077-0	Screw, HHC 1/2-13 UNC X 1 3/4	2
d17-3	M 11/14 M/N	2/3/7/8	**	P2-075-1009-03	Cover, End-SAE B	1
d17-4	M 11/14 M/N	2/3/7/8	**	488-35019-0	Plug, SAE - 20	1
d17-5	M 11/14 M/N	2/3/7/8	1	691-00920-0	Gasket O-ring	1
	M 11/14 M/N	2/3/7/8	4	694-00920-0		
	M 11/14 M/N	2/3/7/8	5	695-00920-0		
D18	M 11/14 M/N	2/3/7/8	**	See Kit P/N Below	Adaptor Assy., Rear Mounting Kit SAE "A"	
d18-1	M 11/14 M/N	2/3/7/8	**	033-92693-0	Coupling, SAE "A"	1
d18-2	M 11/14 M/N	2/3/7/8	1	671-00155-0	Gasket, O-ring	1
	M 11/14 M/N	2/3/7/8	4	674-00155-0		
	M 11/14 M/N	2/3/7/8	5	675-00155-0		
d18-3	M 11/14 M/N	2/3/7/8	**	033-92684-0	Adaptor, Rear Mounting SAE "A"	1
d18-4	M 11/14 M/N	2/3/7/8	**	358-20200-0	Screw, SHC 1/2-13 UNC X 1 1/2	2
d18-5	M 11/14 M/N	2/3/7/8	1	671-00152-0	Gasket, O-ring	1
	M 11/14 M/N	2/3/7/8	4	674-00152-0		
	M 11/14 M/N	2/3/7/8	5	675-00152-0		
d18-6	M 11/14 M/N	2/3/7/8	**	034-59555-0	Cover, Shipping, SAE "A"	1
d18-7	M 11/14 M/N	2/3/7/8	**	306-16120-0	Screw, HHC 3/8-16 X 3/4	2
D18	M 11/14 M/N	2/3/7/8	**	See Kit P/N Below	Adaptor Assy., Rear Mounting Kit SAE "B"	
d18-1	M 11/14 M/N	2/3/7/8	**	033-92982-0	Coupling, SAE "B"	1
d18-2	M 11/14 M/N	2/3/7/8	1	671-00155-0	Gasket, O-ring	1
	M 11/14 M/N	2/3/7/8	4	674-00155-0		
	M 11/14 M/N	2/3/7/8	5	675-00155-0		
d18-3	M 11/14 M/N	2/3/7/8	**	033-92981-0	Adaptor, Rear Mounting SAE "B"	1
d18-4	M 11/14 M/N	2/3/7/8	**	358-24220-0	Screw, SHC 5/8-11 UNC X 1 3/4	4
d18-5	M 11/14 M/N	2/3/7/8	1	671-00155-0	Gasket, O-ring	1
	M 11/14 M/N	2/3/7/8	4	674-00155-0		
	M 11/14 M/N	2/3/7/8	5	675-00155-0		
d18-6	M 11/14 M/N	2/3/7/8	**	034-59556-0	Cover, Shipping, SAE "B"	1
d18-7	M 11/14 M/N	2/3/7/8	**	306-20120-0	Screw, HHC 1/2-13 X 3/4 LG	2
D18	M 11/14 M/N	2/3/4/5	**	See Kit P/N Below	Adaptor Assy., Rear Mounting Kit SAE "C"	
d18-1	M 11/14 M/N	2/3/7/8	**	033-92607-0	Coupling, SAE "C"	1
d18-2	M 11/14 M/N	2/3/7/8	1	671-00155-0	Gasket, O-ring	1
	M 11/14 M/N	2/3/7/8	4	674-00155-0		
	M 11/14 M/N	2/3/7/8	5	675-00155-0		
d18-3	M 11/14 M/N	2/3/7/8	**	033-92555-0	Adaptor, Rear Mounting SAE "C"	1
d18-4	M 11/14 M/N	2/3/7/8	**	358-24220-0	Screw, SHC 5/8-11 UNC X 1 3/4	4
d18-5	M 11/14 M/N	2/3/7/8	1	671-00159-0	Gasket O-ring	1
	M 11/14 M/N	2/3/7/8	4	674-00159-0		
	M 11/14 M/N	2/3/7/8	5	675-00159-0		
d18-6	M 11/14 M/N	2/3/7/8	**	033-57252-0	Cover, Shipping, SAE "C"	1
d18-7	M 11/14 M/N	2/3/7/8	**	358-24160-0	Screw, HHC 5/8-11 UNC X 1	4
M11/14 Motor Type M & N Port Block Assembly (Continued)						
Balloon #	Motor Type	Shaft Code	Seal Code	Item #	Description	Qty

Continued on next page.



D18	M 11/14 M/N	2/3/4/5	**	See Kit P/N Below	Adaptor Assy., Rear Mounting Kit SAE "D"	
d18-1	M 11/14 M/N	2/3/7/8	**	033-92482-0	Coupling, SAE "D & E"	1
d18-2	M 11/14 M/N	2/3/7/8	1	671-00155-0	Gasket, O-ring	1
	M 11/14 M/N	2/3/7/8	4	674-00155-0		
	M 11/14 M/N	2/3/7/8	5	675-00155-0		
d18-3	M 11/14 M/N	2/3/7/8	**	033-92558-0	Adaptor, Rear Mounting SAE "D"	1
d18-4	M 11/14 M/N	2/3/7/8	**	358-24260-0	Screw, SHC 5/8-11 UN	4
d18-5	M 11/14 M/N	2/3/7/8	1	671-00163-0	Gasket O-ring	1
	M 11/14 M/N	2/3/7/8	4	674-00163-0		
	M 11/14 M/N	2/3/7/8	5	675-00163-0		
d18-6	M 11/14 M/N	2/3/7/8	**	034-57250-0	Cover, Shipping, SAE "D"	1
d18-7	M 11/14 M/N	2/3/7/8	**	306-26160-0	Screw, HHC 3/4-10 UNC X 1	2
D18	M 11/14 M/N	2/3/4/5	**	See Kit P/N Below	Adapter Assy., Rear Mounting Kit SAE "E"	
d18-1	M 11/14 M/N	2/3/7/8	**	033-92482-0	Coupling, SAE "D & E"	1
d18-2	M 11/14 M/N	2/3/7/8	1	671-00155-0	Gasket, O-ring	1
	M 11/14 M/N	2/3/7/8	4	674-00155-0		
	M 11/14 M/N	2/3/7/8	5	675-00155-0		
d18-3	M 11/14 M/N	2/3/7/8	**	033-92467-0	Adaptor, Rear Mounting SAE "E"	1
d18-4	M 11/14 M/N	2/3/7/8	**	358-24260-0	Screw, SHC 5/8-11 UN	4
d18-5	M 11/14 M/N	2/3/7/8	1	671-00165-0	Gasket O-ring	1
	M 11/14 M/N	2/3/7/8	4	674-00165-0		
	M 11/14 M/N	2/3/7/8	5	675-00165-0		
d18-6	M 11/14 M/N	2/3/7/8	**	034-91405-0	Cover, Shipping, SAE "E"	1
d18-7	M 11/14 M/N	2/3/7/8	**	306-26160-0	Screw, HHC 3/4-10 UNC X 1	2
D19	M 11/14 M/N	2/3/7/8	1	691-00912-0	Gasket O-ring	2
	M 11/14 M/N	2/3/7/8	4	694-00912-0		
	M 11/14 M/N	2/3/7/8	5	695-00912-0		
D20	M 11/14 M/N	2/3/7/8	**	488-35014-0	Plug, HP5N-S SAE-12	2
D22	M 11/14 M	2/3/7/8	**	See Kit P/N Below	Adapter, Shuttle Blanking Cover Plate Assy.	
d22-1	M 11/14 M	2/3/7/8	1	691-00024-0	Gasket O-ring	2
d22-2	M 11/14 M	2/3/7/8	4	694-00024-0		
	M 11/14 M	2/3/7/8	5	695-00024-0		
	M 11/14 M	2/3/7/8	1	691-00015-0	Gasket O-ring	1
	M 11/14 M	2/3/7/8	4	694-00015-0		
	M 11/14 M	2/3/7/8	5	695-00015-0		
d22-3	M 11/14 M	2/3/7/8	**	033-57642-0	Adapter, Plate Shuttle Lg to SM	1
d22-4	M 11/14 M	2/3/7/8	**	306-40080-0	Screw, HHC 1/2-13 UNC X 1 1/4	4
D23	M 11/14 N	2/3/7/8	**	See Kit P/N Below	Adapter, Ass'y Shuttle Lg to SM	
d23-1	M 11/14 N	2/3/7/8	1	691-00024-0	Gasket O-ring	2
d23-2	M 11/14 N	2/3/7/8	4	694-00024-0		
	M 11/14 N	2/3/7/8	5	695-00024-0		
	M 11/14 N	2/3/7/8	1	691-00015-0	Gasket O-ring	1
	M 11/14 N	2/3/7/8	4	694-00015-0		
	M 11/14 N	2/3/7/8	5	695-00015-0		
d23-3	M 11/14 N	2/3/7/8	**	033-93734-0	Adapter, Plate Shuttle Lg to SM	1
d23-4	M 11/14 N	2/3/7/8	**	358-20160-0	Screw, SHC 1/2-13 UNC X 1	4

Rear Drive Hard Cover "Operating" Adapter Kit Assembly			
Contains all items d17-1 thru d17-5			
Rear Mounting	Motor	Seal Code	Part Number
SAE "A"	M 11/14 M/N	1	S21-04526-0
SAE "A"	M 11/14 M/N	4	S21-04526-4
SAE "A"	M 11/14 M/N	5	S21-04526-5

Optional Rear Drive Adapter Kit Assemblies			
Contains all items d18-1 thru d18-5			
Rear Mounting	Motor	Seal Code	Part Number
SAE "A"	M 11/14 M/N	1	S23-16250-0
SAE "A"	M 11/14 M/N	4	S23-16250-4
SAE "A"	M 11/14 M/N	5	S23-16250-5
SAE "B"	M 11/14 M/N	1	S23-16251-0
SAE "B"	M 11/14 M/N	4	S23-16251-4
SAE "B"	M 11/14 M/N	5	S23-16251-5
SAE "C"	M 11/14 M/N	1	S23-16252-0
SAE "C"	M 11/14 M/N	4	S23-16252-4
SAE "C"	M 11/14 M/N	5	S23-16252-5
SAE "D"	M 11/14 M/N	1	S23-16253-0
SAE "D"	M 11/14 M/N	4	S23-16253-4
SAE "D"	M 11/14 M/N	5	S23-16253-5
SAE "E"	M 11/14 M/N	1	S23-16254-0
SAE "E"	M 11/14 M/N	4	S23-16254-4
SAE "E"	M 11/14 M/N	5	S23-16254-5

Port Block Assembly machined for shuttle mounting		
The following Kit contains items D3,D5,D6, D7, D10, D19, & D20		
Shaft Code	Motor Type	Part Number
2/3/7/8	M 11/14 M/N	S23-16715-0

Shuttle Assembly Kit (without orifices)		
The following Kit contains items d9-1 thru d9-14		
Shaft Code	Motor Type	Part Number
2/3/7/8	M 11/14 N	S13-48273-0

Shuttle Assembly Kit (with orifices)		
The following Kit contains items d9-1 thru d9-15		
Shaft Code	Motor Type	Part Number
2/3/7/8	M 11/14 N	S13-48776-0

Shipping Port Cover Kit		
The following Kit contains items d11-1 and d11-2		
Shaft Code	Motor Type	Part Number
2/3/7/8	M 11/14 F/G/M/N	S13-26133-0

Cover Assembly, Blanking Plate for Shuttle		
The following Kit contains items d22-1 thru d22-4		
Shaft Code	Motor Type	Part Number
2/3/7/8	M 11/14 M	S23-11843-0

Adapter, Ass'y Shuttle Lg to SM		
The following Kit contains items d23-1 thru d23-4		
Shaft Code	Motor Type	Part Number
2/3/7/8	M 11/14 N	S23-17630-0



The items described in this document and other documents and descriptions provided by Parker Hannifin Corporation, Hydraulics Group, and its authorized distributors ("Seller") are hereby offered for sale at prices to be established by Seller. This offer and its acceptance by any customer ("Buyer") shall be governed by all of the following Terms and Conditions. Buyer's order for any item described in its document, when communicated to Seller verbally, or in writing, shall constitute acceptance of this offer. All goods or work described will be referred to as "Products".

1. **Terms and Conditions.** Seller's willingness to offer Products, or accept an order for Products, to or from Buyer is expressly conditioned on Buyer's assent to these Terms and Conditions and to the terms and conditions found on-line at www.parker.com/saleterms/. Seller objects to any contrary or additional term or condition of Buyer's order or any other document issued by Buyer.
2. **Price Adjustments; Payments.** Prices stated on the reverse side or preceding pages of this document are valid for 30 days. After 30 days, Seller may change prices to reflect any increase in its costs resulting from state, federal or local legislation, price increases from its suppliers, or any change in the rate, charge, or classification of any carrier. The prices stated on the reverse or preceding pages of this document do not include any sales, use, or other taxes unless so stated specifically. Unless otherwise specified by Seller, all prices are F.O.B. Seller's facility, and payment is due 30 days from the date of invoice. After 30 days, Buyer shall pay interest on any unpaid invoices at the rate of 1.5% per month or the maximum allowable rate under applicable law.
3. **Delivery Dates; Title and Risk; Shipment.** All delivery dates are approximate and Seller shall not be responsible for any damages resulting from any delay. Regardless of the manner of shipment, title to any products and risk of loss or damage shall pass to Buyer upon tender to the carrier at Seller's facility (i.e., when it's on the truck, it's yours). Unless otherwise stated, Seller may exercise its judgment in choosing the carrier and means of delivery. No deferment of shipment at Buyers' request beyond the respective dates indicated will be made except on terms that will indemnify, defend and hold Seller harmless against all loss and additional expense. Buyer shall be responsible for any additional shipping charges incurred by Seller due to Buyer's changes in shipping, product specifications or in accordance with Section 13, herein.
4. **Warranty.** Seller warrants that the Products sold hereunder shall be free from defects in material or workmanship for a period of eighteen months from the date of delivery to Buyer. The prices charged for Seller's products are based upon the exclusive limited warranty stated above, and upon the following disclaimer: **DISCLAIMER OF WARRANTY: THIS WARRANTY COMPRISES THE SOLE AND ENTIRE WARRANTY PERTAINING TO PRODUCTS PROVIDED HEREUNDER. SELLER DISCLAIMS ALL OTHER WARRANTIES, EXPRESS AND IMPLIED, INCLUDING MERCHANTABILITY AND FITNESS FOR A PARTICULAR PURPOSE.**
5. **Claims; Commencement of Actions.** Buyer shall promptly inspect all Products upon delivery. No claims for shortages will be allowed unless reported to the Seller within 10 days of delivery. No other claims against Seller will be allowed unless asserted in writing within 60 days after delivery or, in the case of an alleged breach of warranty, within 30 days after the date within the warranty period on which the defect is or should have been discovered by Buyer. Any action based upon breach of this agreement or upon any other claim arising out of this sale (other than an action by Seller for any amount due to Seller from Buyer) must be commenced within thirteen months from the date of tender of delivery by Seller or, for a cause of action based upon an alleged breach of warranty, within thirteen months from the date within the warranty period on which the defect is or should have been discovered by Buyer.
6. **LIMITATION OF LIABILITY. UPON NOTIFICATION, SELLER WILL, AT ITS OPTION, REPAIR OR REPLACE A DEFECTIVE PRODUCT, OR REFUND THE PURCHASE PRICE. IN NO EVENT SHALL SELLER BE LIABLE TO BUYER FOR ANY SPECIAL, INDIRECT, INCIDENTAL OR CONSEQUENTIAL DAMAGES ARISING OUT OF, OR AS THE RESULT OF, THE SALE, DELIVERY, NON-DELIVERY, SERVICING, USE OR LOSS OF USE OF THE PRODUCTS OR ANY PART THEREOF, OR FOR ANY CHARGES OR EXPENSES OF ANY NATURE INCURRED WITHOUT SELLER'S WRITTEN CONSENT, EVEN IF SELLER HAS BEEN NEGLIGENT, WHETHER IN CONTRACT, TORT OR OTHER LEGAL THEORY. IN NO EVENT SHALL SELLER'S LIABILITY UNDER ANY CLAIM MADE BY BUYER EXCEED THE PURCHASE PRICE OF THE PRODUCTS.**
7. **Contingencies.** Seller shall not be liable for any default or delay in performance if caused by circumstances beyond the reasonable control of Seller.
8. **User Responsibility.** The user, through its own analysis and testing, is solely responsible for making the final selection of the system and Product and assuring that all performance, endurance, maintenance, safety and warning requirements of the application are met. The user must analyze all aspects of the application and follow applicable industry standards and Product information. If Seller provides Product or system options, the user is responsible for determining that such data and specifications are suitable and sufficient for all applications and reasonably foreseeable uses of the Products or systems.
9. **Loss to Buyer's Property.** Any designs, tools, patterns, materials, drawings, confidential information or equipment furnished by Buyer or any other items which become Buyer's property, may be considered obsolete and may be destroyed by Seller after two consecutive years have elapsed without Buyer placing an order for the items which are manufactured using such property. Seller shall not be responsible for any loss or damage to such property while it is in Seller's possession or control.
10. **Special Tooling.** A tooling charge may be imposed for any special tooling, including without limitation, dies, fixtures, molds and patterns, acquired to manufacture Products. Such special tooling shall be and remain Seller's property notwithstanding payment of any charges by Buyer. In no event will Buyer acquire any interest in apparatus belonging to Seller which is utilized in the manufacture of the Products, even if such apparatus has been specially converted or adapted for such manufacture and notwithstanding any charges paid by Buyer. Unless otherwise agreed, Seller shall have the right to alter, discard or otherwise dispose of any special tooling or other property in its sole discretion at any time.
11. **Buyer's Obligation; Rights of Seller.** To secure payment of all sums due or otherwise, Seller shall retain a security interest in the goods delivered and this agreement shall be deemed a Security Agreement under the Uniform Commercial Code. Buyer authorizes Seller as its attorney to execute and file on Buyer's behalf all documents Seller deems necessary to perfect its security interest. Seller shall have a security interest in, and lien upon, any property of Buyer in Seller's possession as security for the payment of any amounts owed to Seller by Buyer.
12. **Improper Use and Indemnity.** Buyer shall indemnify, defend, and hold Seller harmless from any claim, liability, damages, lawsuits, and costs (including attorney fees), whether for personal injury, property damage, patent, trademark or copyright infringement or any other claim, brought by or incurred by Buyer, Buyer's employees, or any other person, arising out of: (a) improper selection, improper application or other misuse of Products purchased by Buyer from Seller; (b) any act or omission, negligent or otherwise, of Buyer; (c) Seller's use of patterns, plans, drawings, or specifications furnished by Buyer to manufacture Product; or (d) Buyer's failure to comply with these terms and conditions. Seller shall not indemnify Buyer under any circumstance except as otherwise provided.
13. **Cancellations and Changes.** Orders shall not be subject to cancellation or change by Buyer for any reason, except with Seller's written consent and upon terms that will indemnify, defend and hold Seller harmless against all direct, incidental and consequential loss or damage. Seller may change product features, specifications, designs and availability with notice to Buyer.
14. **Limitation on Assignment.** Buyer may not assign its rights or obligations under this agreement without the prior written consent of Seller.
15. **Entire Agreement.** This agreement contains the entire agreement between the Buyer and Seller and constitutes the final, complete and exclusive expression of the terms of the agreement. All prior or contemporaneous written or oral agreements or negotiations with respect to the subject matter are herein merged.
16. **Waiver and Severability.** Failure to enforce any provision of this agreement will not waive that provision nor will any such failure prejudice Seller's right to enforce that provision in the future. Invalidation of any provision of this agreement by legislation or other rule of law shall not invalidate any other provision herein. The remaining provisions of this agreement will remain in full force and effect.
17. **Termination.** This agreement may be terminated by Seller for any reason and at any time by giving Buyer thirty (30) days written notice of termination. In addition, Seller may by written notice immediately terminate this agreement for the following: (a) Buyer commits a breach of any provision of this agreement (b) the appointment of a trustee, receiver or custodian for all or any part of Buyer's property (c) the filing of a petition for relief in bankruptcy of the other Party on its own behalf, or by a third party (d) an assignment for the benefit of creditors, or (e) the dissolution or liquidation of the Buyer.
18. **Governing Law.** This agreement and the sale and delivery of all Products hereunder shall be deemed to have taken place in and shall be governed and construed in accordance with the laws of the State of Ohio, as applicable to contracts executed and wholly performed therein and without regard to conflicts of laws principles. Buyer irrevocably agrees and consents to the exclusive jurisdiction and venue of the courts of Cuyahoga County, Ohio with respect to any dispute, controversy or claim arising out of or relating to this agreement. Disputes between the parties shall not be settled by arbitration unless, after a dispute has arisen, both parties expressly agree in writing to arbitrate the dispute.
19. **Indemnity for Infringement of Intellectual Property Rights.** Seller shall have no liability for infringement of any patents, trademarks, copyrights, trade dress, trade secrets or similar rights except as provided in this Section. Seller will defend and indemnify Buyer against allegations of infringement of U.S. patents, U.S. trademarks, copyrights, trade dress and trade secrets ("Intellectual Property Rights"). Seller will defend at its expense and will pay the cost of any settlement or damages awarded in an action brought against Buyer based on an allegation that a Product sold pursuant to this Agreement infringes the Intellectual Property Rights of a third party. Seller's obligation to defend and indemnify Buyer is contingent on Buyer notifying Seller within ten (10) days after Buyer becomes aware of such allegations of infringement, and Seller having sole control over the defense of any allegations or actions including all negotiations for settlement or compromise. If a Product is subject to a claim that it infringes the Intellectual Property Rights of a third party, Seller may, at its sole expense and option, procure for Buyer the right to continue using the Product, replace or modify the Product so as to make it noninfringing, or offer to accept return of the Product and return the purchase price less a reasonable allowance for depreciation. Notwithstanding the foregoing, Seller shall have no liability for claims of infringement based on information provided by Buyer, or directed to Products delivered hereunder for which the designs are specified in whole or part by Buyer, or infringements resulting from the modification, combination or use in a system of any Product sold hereunder. The foregoing provisions of this Section shall constitute Seller's sole and exclusive liability and Buyer's sole and exclusive remedy for infringement of Intellectual Property Rights.
20. **Taxes.** Unless otherwise indicated, all prices and charges are exclusive of excise, sales, use, property, occupational or like taxes which may be imposed by any taxing authority upon the manufacture, sale or delivery of Products.
21. **Equal Opportunity Clause.** For the performance of government contracts and where dollar value of the Products exceed \$10,000, the equal employment opportunity clauses in Executive Order 11246, VEVRRA, and 41 C.F.R. §§ 60-1.4(a), 60-741.5(a), and 60-250.4, are hereby incorporated.



North America

Industrial

USA

Chicago Region

Naperville, IL
Tel: (630) 964 0796

Great Lakes Region

Fairlawn, OH
Tel: (330) 670 2680

Northeast Region

Lebanon, NJ
Tel: (908) 236 4121

Pacific Region

Buena Park, CA
Tel: (714) 228 2509

Southern Region

Alpharetta, GA
Tel: (770) 619 9767

Canada

Milton, Ontario
Tel: (905) 693 3000

México

Toluca, Edo. de México
Tel: (52) 72 2275 4200

Mobile

USA

Global Mobile

Lincolnshire, IL
Tel: (847) 821 1500

Central Region

Lincolnshire, IL
Tel: (847) 821 1500

Eastern Region

North Canton, OH
Tel: (330) 284 3355

Midwest Region

Hiawatha, IA
Tel: (319) 393 1221

Southern Region

Aledo, TX
Tel: (817) 441 1794

Western Region

Buena Park, CA
Tel: (714) 228 2509

Canada

Milton, Ontario
Tel: (905) 693 3000

México

Apodaca, N.L.
Tel: (52) 81 8156 6000

Truck

USA

Eastern Region

Cleveland, OH
Tel: (440) 519 1125

Western Region

San Ramon, CA
Tel: (925) 735 9573

Canada

Milton, Ontario
Tel: (905) 693 3000

México

Apodaca, N.L.
Tel: (52) 81 8156 6000

Europe

Austria

Wiener Neustadt
Tel: (43) 2622 23501 0

Belgium

Nivelles
Tel: (32) 67 280 900

Czech Republic and Slovakia

Klecany
Tel: (420) 284 083 111

Denmark

Ballerup
Tel: (45) 4356 0400

Finland

Vantaa
Tel: (358) 20 753 2500

France

Contamine-sur-Arve
Tel: (33) 4 50 25 80 25

Germany

Kaarst
Tel: (49) 2131 4016 0

Greece

Athens
Tel: (30) 210 933 6450

Hungary

Budapest
Tel: (36) 1 220 4155

Ireland

County Dublin, Baldonnell
Tel: (353) 1 466 6370

Italy

Corsico, Milano
Tel: (39) 02 45 19 21

The Netherlands

Oldenzaal
Tel: (31) 541 585000

Norway

Ski
Tel: (47) 64 91 10 00

Poland

Warsaw
Tel: (48) 22 57 32400

Portugal

Leca da Palmeira
Tel: (351) 22 999 7360

Romania

Bucharest
Tel: (40) 21 252 1382

Russia

Moscow
Tel: (7) 495 580 9145

Slovenia

Novo Mesto
Tel: (386) 7 337 6650

Spain

Madrid
Tel: (34) 91 675 7300

Sweden

Spanga
Tel: (46) 8 597 95000

Ukraine

Kiev
Tel: (380) 44 494 2731

United Kingdom

Warwick,
Tel: (44) 1926 317878

Asia Pacific

Australia

Castle Hill
Tel: (61) 2 9634 7777

China

Beijing
Tel: (86) 10 6561 0520

Shanghai

Tel: (86) 21 5031 2525

Hong Kong

Tel: (852) 2428 8008

India

Mahape, Navi Mumbai
Tel: (91) 22 5613 7081

Korea

Seoul
Tel: (82) 2 559 0400

Malaysia

Subang Jaya
Tel: (60) 3 5638 1476

New Zealand

Mt. Wellington
Tel: (64) 9 574 1744

Japan

Tokyo
Tel: (81) 3 6408 3900

Singapore

Jurong Town
Tel: (65) 6 887 6300

Taiwan

Taipei
Tel: (886) 2 2298 8987

Thailand

Bangkok
Tel: (662) 717 8140

Middle East

United Arab Emirates

Abu Dhabi
Tel: (971) 2 678 8587

Latin America

Pan American Division

Miami, FL
Tel: (305) 470 8800

Argentina

Buenos Aires
Tel: (54) 33 2744 4129

Brazil

Cachoeirinha RS
Tel: (55) 51 3470 9144

Venezuela

Caracas
Tel: (58) 212 238 5422

Africa

South Africa

Kempton Park
Tel: (27) 11 961 0700

